

ASSEMBLY INSTRUCTIONS / NOTICE D'ASSEMBLAGE

ITEM : WM#3110-DT/ASTRBDTL

Important note/ Note importante:

1. Place all wooden parts on a clean and smooth surface such as a rug or carpet to avoid scratching the parts. / Placer les pièces sur une surface propre et lisse tel qu'une couverture ou un tapis pour éviter d'endommager les pièces.
2. Kindly follow the assembly instructions step by step./ Veuillez suivre la notice d'assemblage, pas à pas.
3. Do not tighten all screws and bolts until the table is fully assembled./ Ne serrer les vis et boulons à fond que lorsque le produit est entièrement assemblé.
4. Unscrew the protective plastic supports from the metal insert of the table legs before assembly./ Dévisser les caches plastiques des embouts métalliques des pieds de la table avant l'assemblage.

PARTS IDENTIFICATION / IDENTIFICATION DES PIÈCES

A Table Top
Dessus de Table



1pc

B Leg
Pied

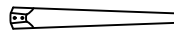

4pcs

HARDWARE IDENTIFICATION / IDENTIFICATION DES PIÈCES MONTAGE

1 Bolt
Boulon
Ø3/8"X70mm



8pcs

2 Spring Washer
Rondelle D'arret
Ø3/8"X13mm



8pcs

3 Flat Washer
Rondelle Plate
Ø3/8"X22mm



8pcs

4 Allen Key
Clé Allen
M5 X 65mm



1pc

STEP 1 / ÉTAPE 1

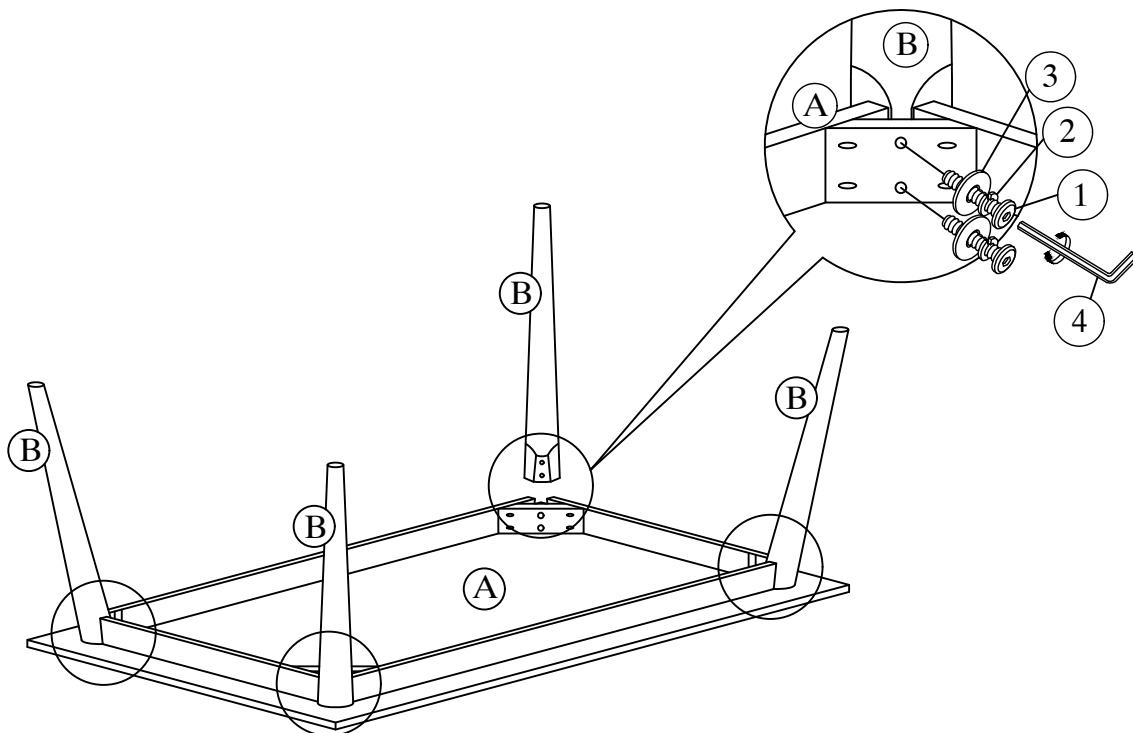

ASSEMBLY INSTRUCTIONS / NOTICE D'ASSEMBLAGE
ITEM : WM#3110-DT/ASTRBDTL

COMPLETED

