

ASSEMBLY INSTRUCTIONS (INSTRUCTIONS D'ASSEMBLAGE)

HARDWARE LIST (LISTE DES OUTILS):

NO.	SKETCH	DESCRIPTION	QTY
A		Bolt(1/4"*1") Boulon	8 PCS
B		Bolt(1/4"*2") Boulon	8 PCS
C		Washer(1/4"*φ16) Rondelle plate	16 PCS
D		Spring Washer(1/4") Rondelle frein	16 PCS
E		Allen wrench(4mm) Clé hexagonale	1 PC

PARTS LIST (LISTE DES PIECES):

NO.	SKETCH	DESCRIPTION	QTY
1		Table top Dessus de table	1 PC
2		Leg Pied	4 PCS

Step 1 / Étape 1

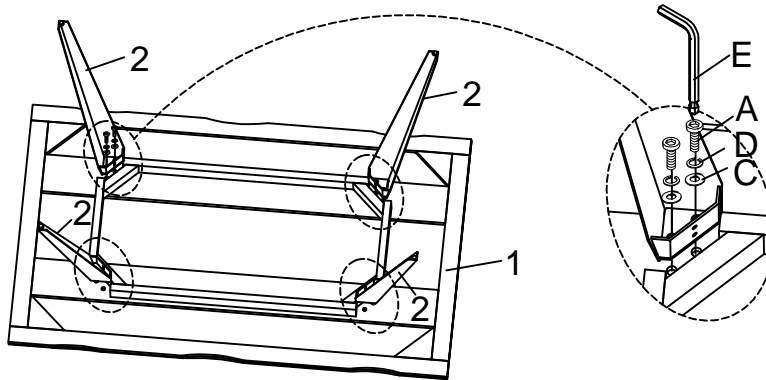

Note: At this stage, do not fully tighten the bolts .

À noter qu'il ne faut pas serrer complètement les boulons à ce stade.

Step 2 / Étape 2

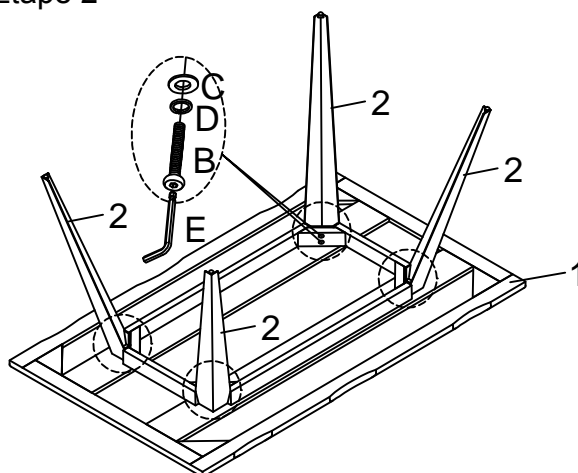

Note: Do not full tighten all bolts until complete assembly.

Tel qu' illustré. Attendre avant de serrer complètement les boulons.

ASSEMBLY INSTRUCTIONS (INSTRUCTIONS D'ASSEMBLAGE)

Step 3 / Étape 3

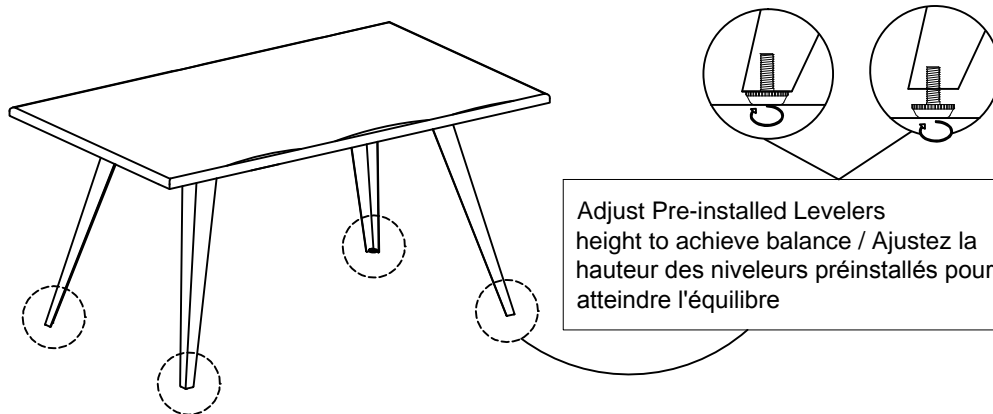

Step 4 / Étape 4

