

ASSEMBLY INSTRUCTIONS /
INSTRUCTIONS D'ASSEMBLAGE

ITEM NO/NO ARTICLE: ALELGAC/253335

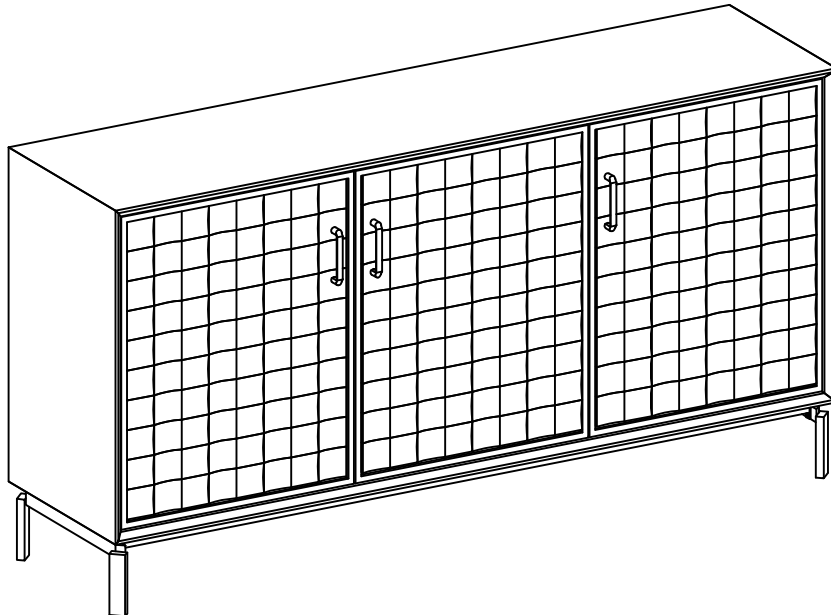

PARTS IDENTIFICATIONS / IDENTIFICATION DES PIECES



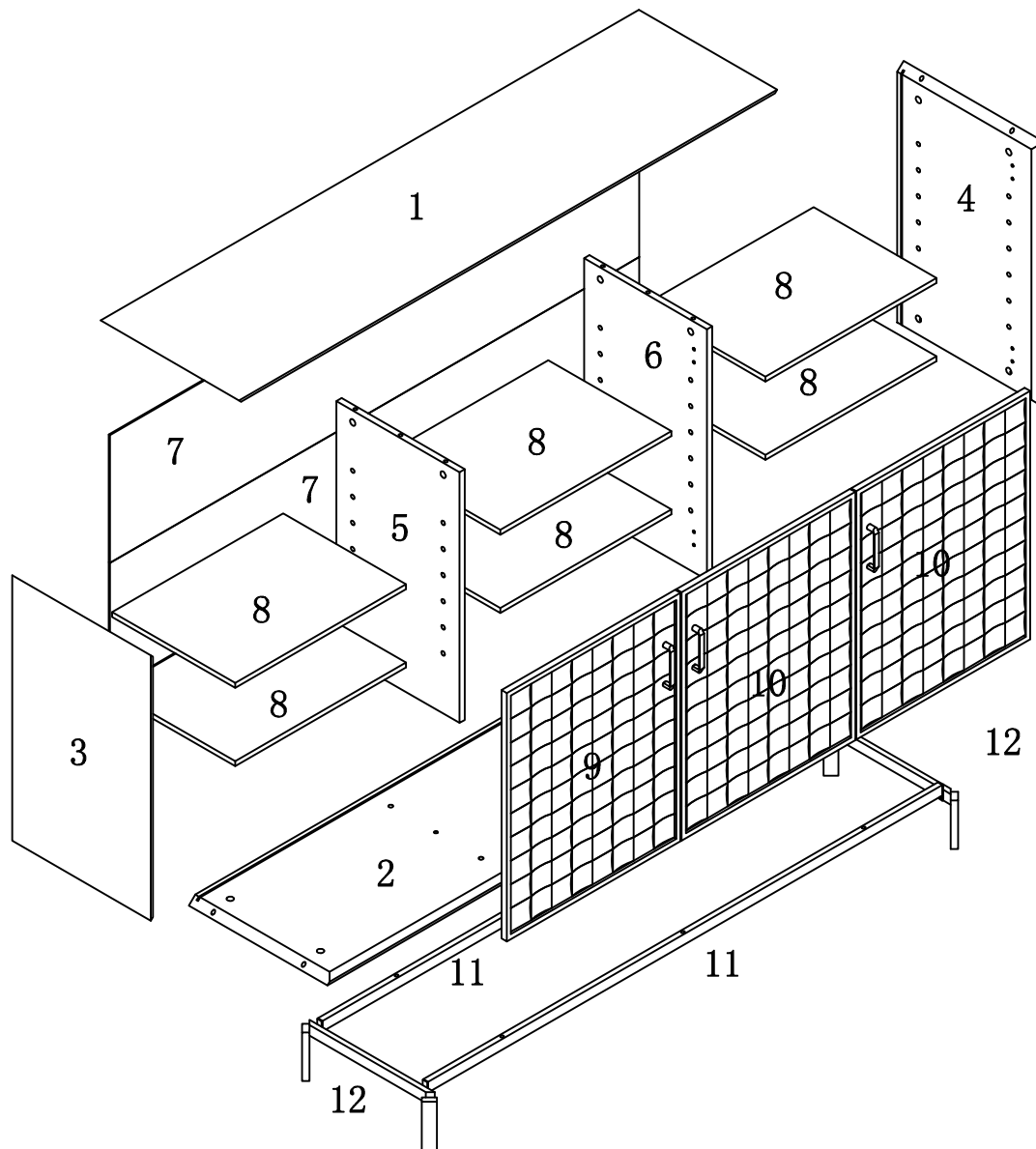







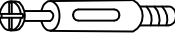

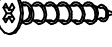







ITEM NO/NO ARTICLE:ALELGAC/253335



(1)	1pc/pce	(7)	2pcs/pces
(2)	1pc/pce	(8)	6pcs/pces
(3)	1pc/pce	(9)	1pc/pce
(4)	1pc/pce	(10)	2pcs/pce
(5)	1pc/pce	(11)	2pcs/pces
(6)	1pc/pce	(12)	2pcs/pces

HARDWARE IDENTIFICATIONS/ IDENTIFICATION DU KIT D'ASSEMBLAGE

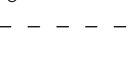
ITEM NO/NO ARTICLE:ALELGAC/253335

A		Φ 15	20pcs/pces
B		L29	4pcs/pces
C		Φ 8x25	4pcs/pces
D		Φ 22	20pcs/pces
E		Φ 4x35	4pcs/pces
F		Φ 8x45	8pcs/pces
G			8pcs/pces
H		Φ 6x10	4pcs/pces
I		Φ 6x30	6pcs/pces
J			24pcs/pces
K		301C	4pcs/pces
L		Φ 3.5x12	36pcs/pces
M		301B	2pcs/pces
N		96#	3pcs/pces
O		Φ 4x22	6pcs/pces
P			16pcs/pces
Q		Φ 3x16	16pcs/pces
R		197x5x1	1pcs/pce
S		Φ 8x40	1pcs/pce
T		12x12x1	2pcs/pces
U		Φ 5x40	1pcs/pce
V		Φ 4x25	1pcs/pce

ITEM NO/NO ARTICLE: ALELGAC/253335

STEP 1 / ETAPE 1

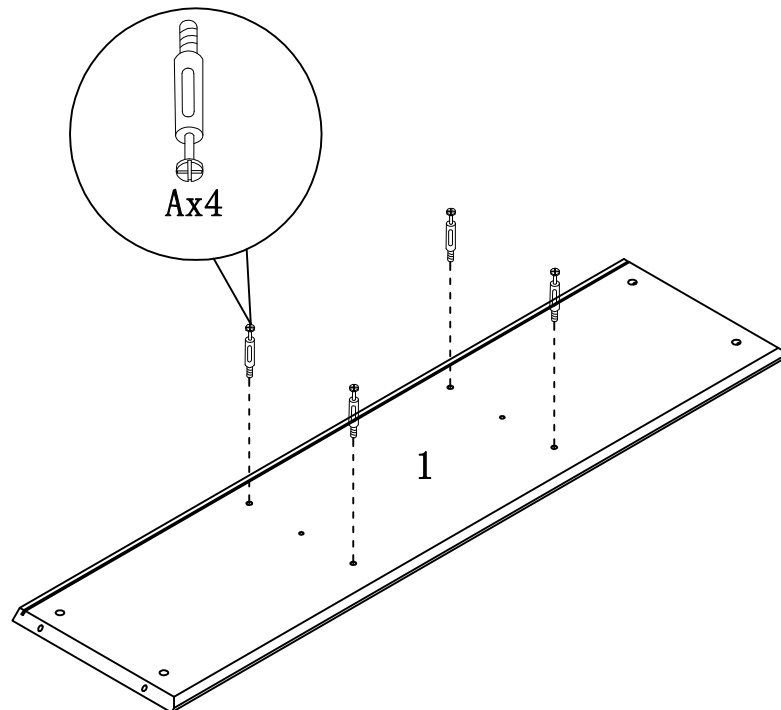

STEP 2 / ETAPE 2

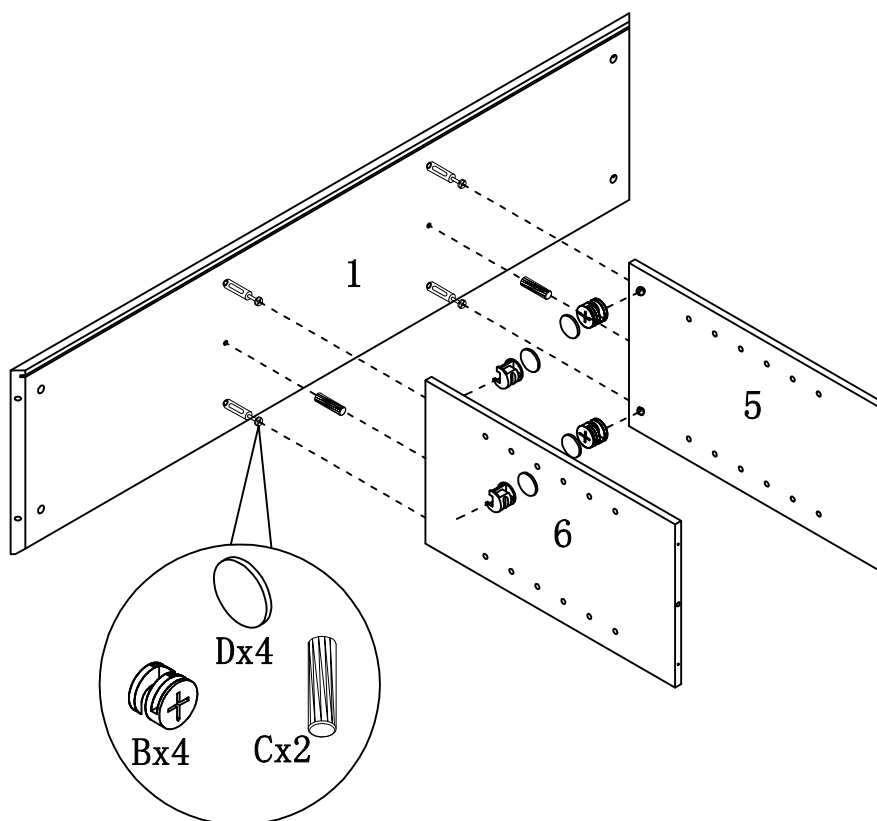

ITEM NO/NO ARTICLE: ALELGAC/253335

STEP 3 / ETAPE 3

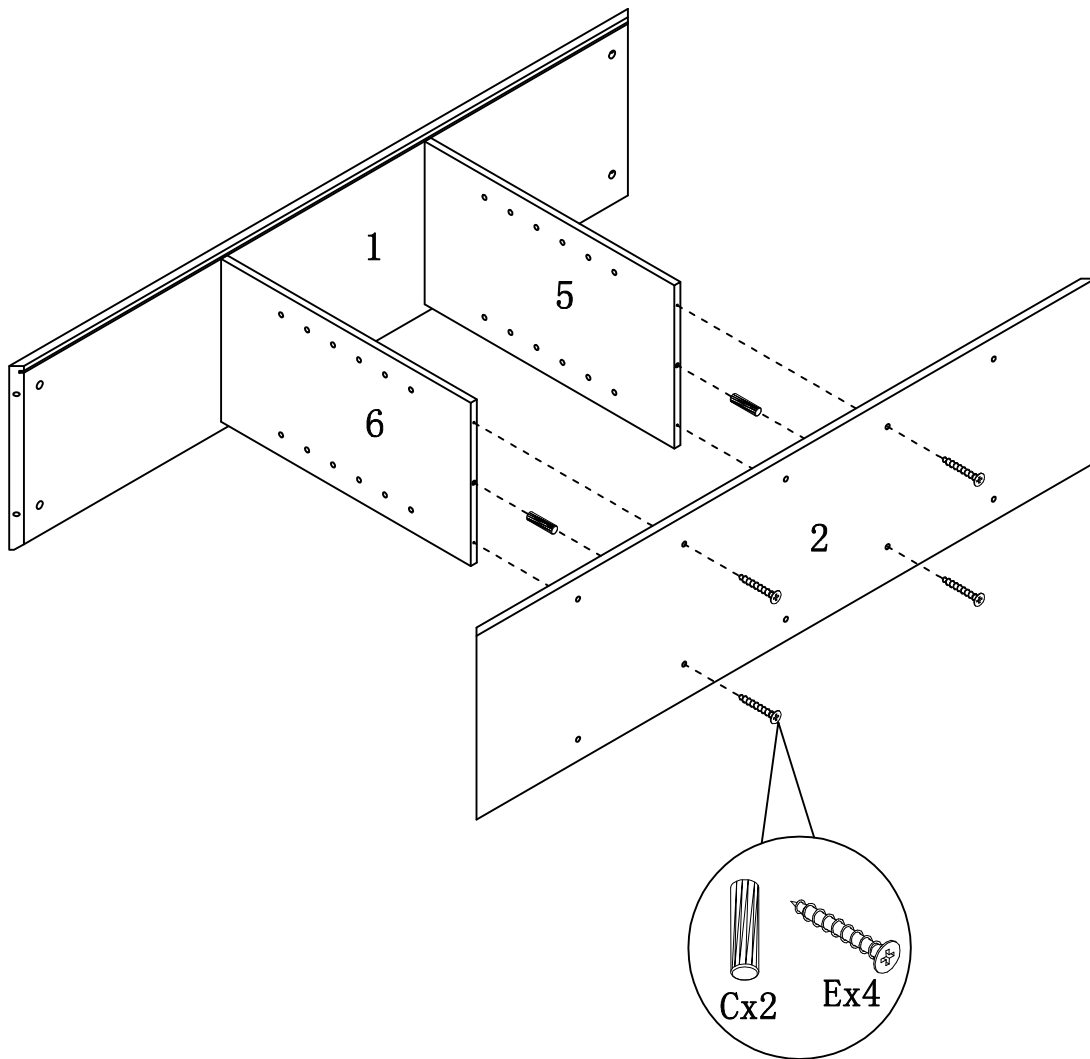

ITEM NO/NO ARTICLE: ALELGAC/253335

STEP 4 / ETAPE 4

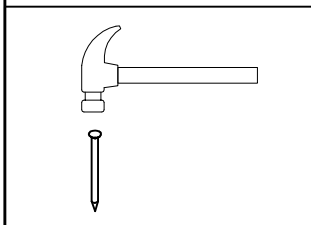
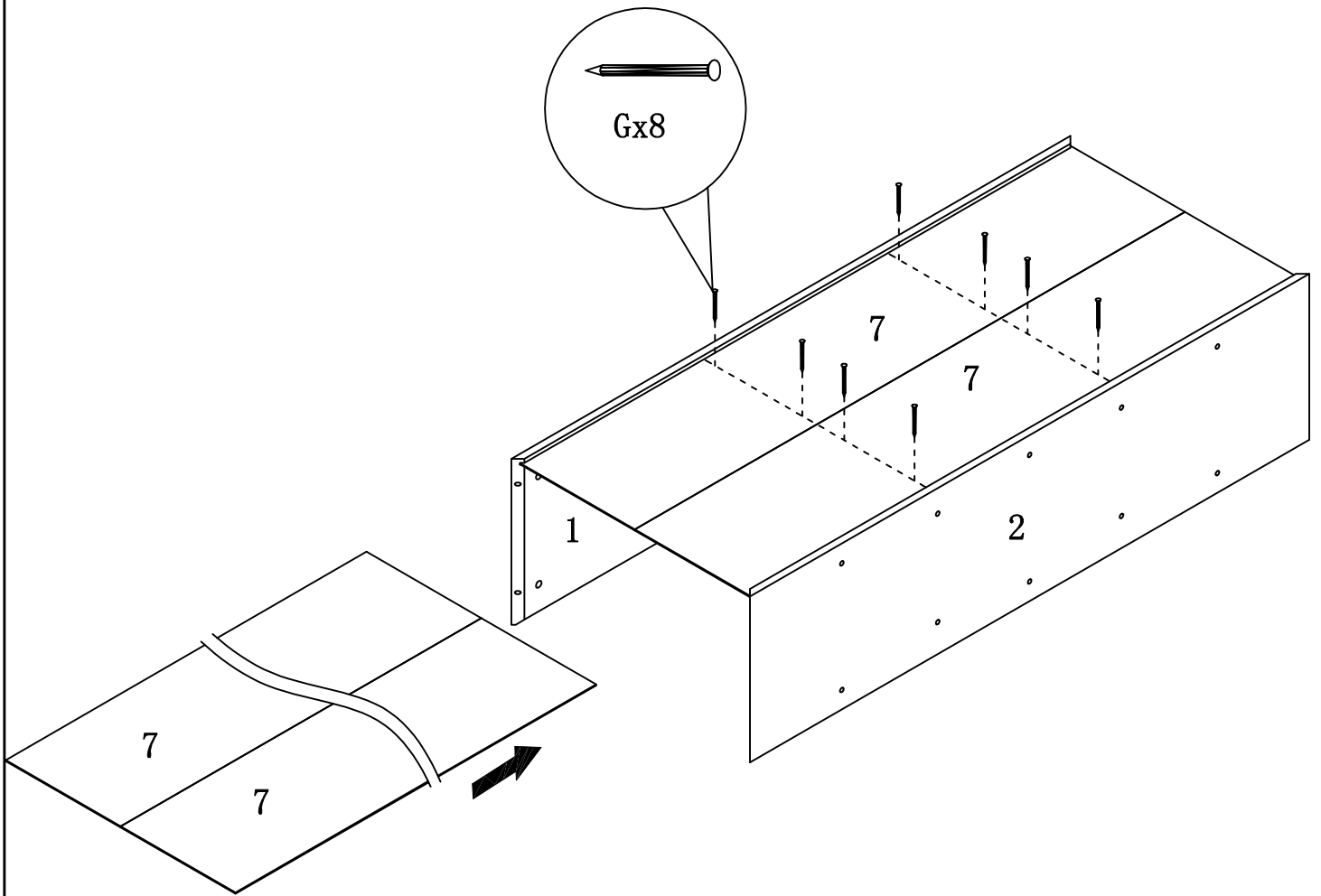

ITEM NO/NO ARTICLE: ALELGAC/253335

STEP 5 / ETAPE 5

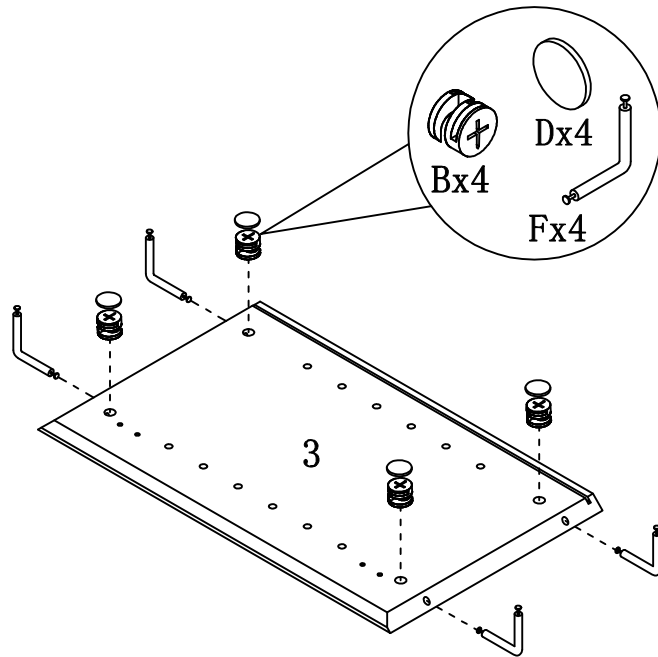

STEP 6 / ETAPE 6

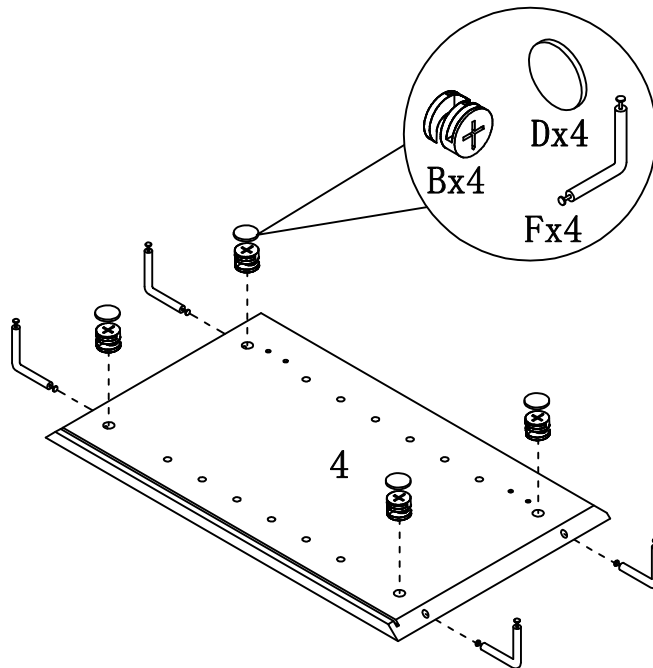

ITEM NO/NO ARTICLE: ALELGAC/253335

STEP 7 / ETAPE 7

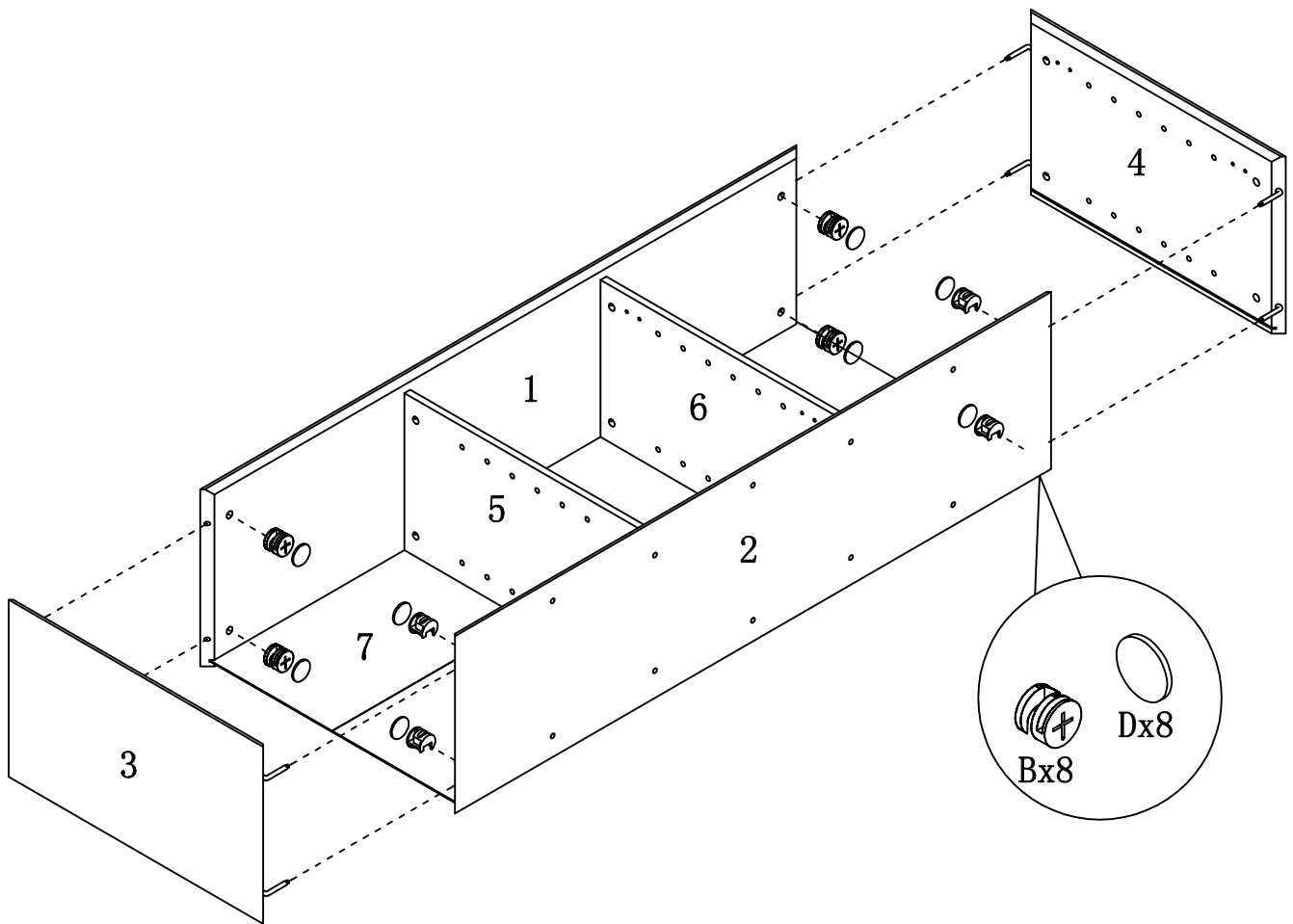

ITEM NO/NO ARTICLE: ALELGAC/253335

STEP 8 / ETAPE 8

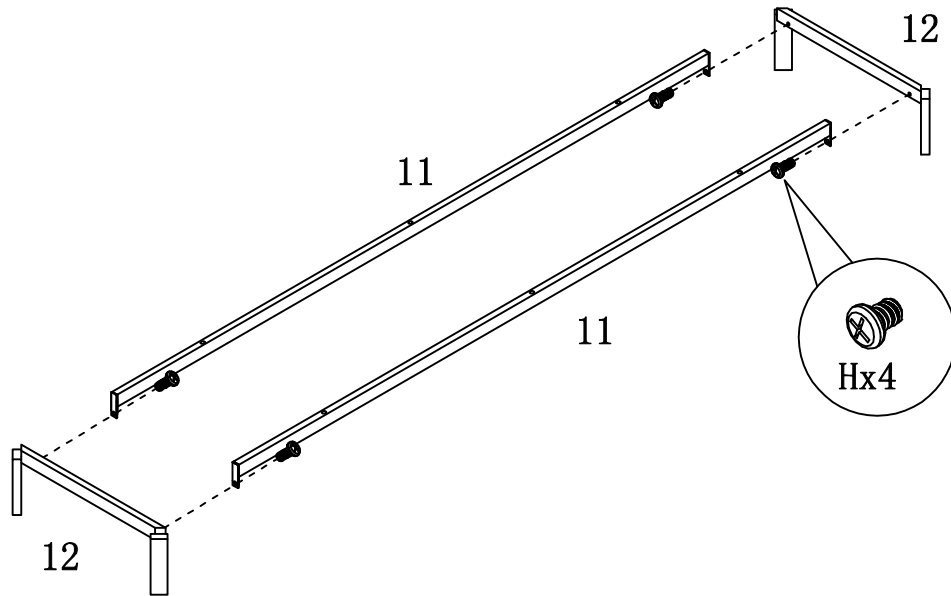

STEP 9 / ETAPE 9

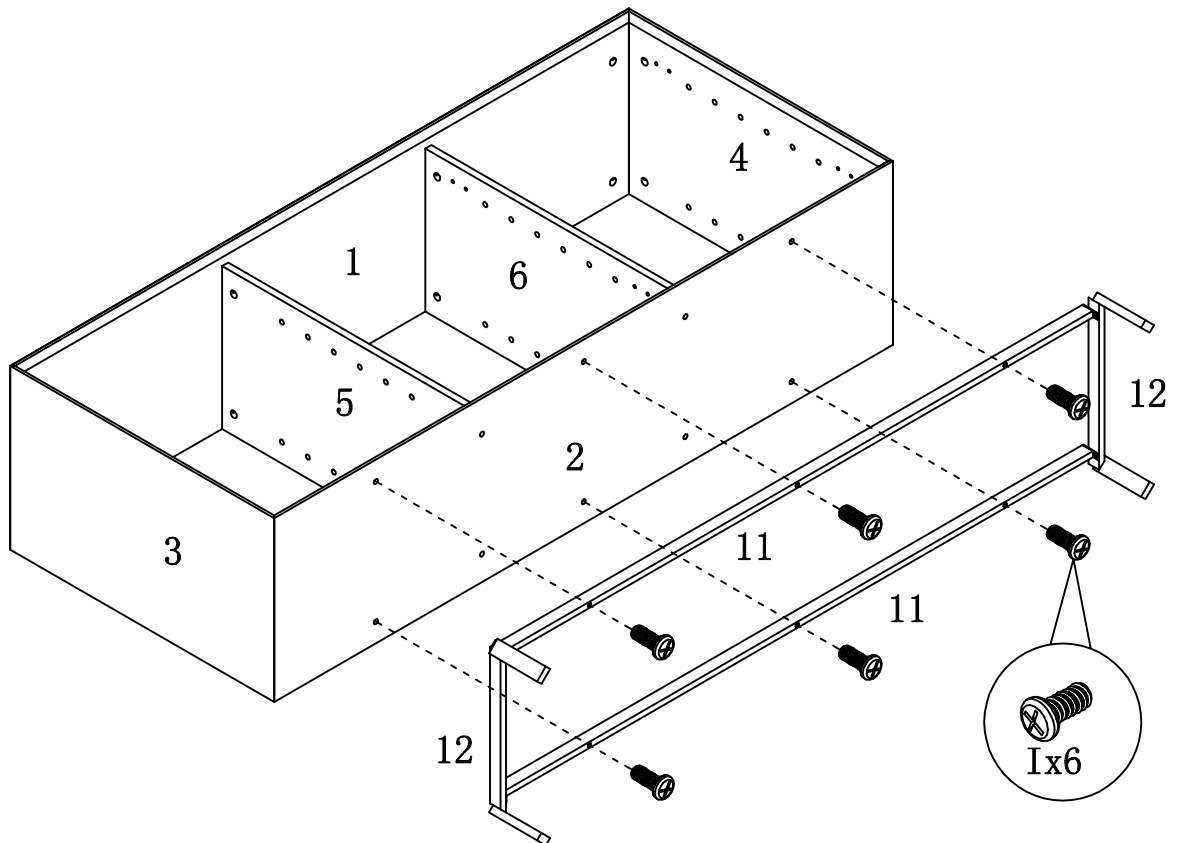

ITEM NO/NO ARTICLE: ALELGAC/253335

STEP 10 / ETAPE 10

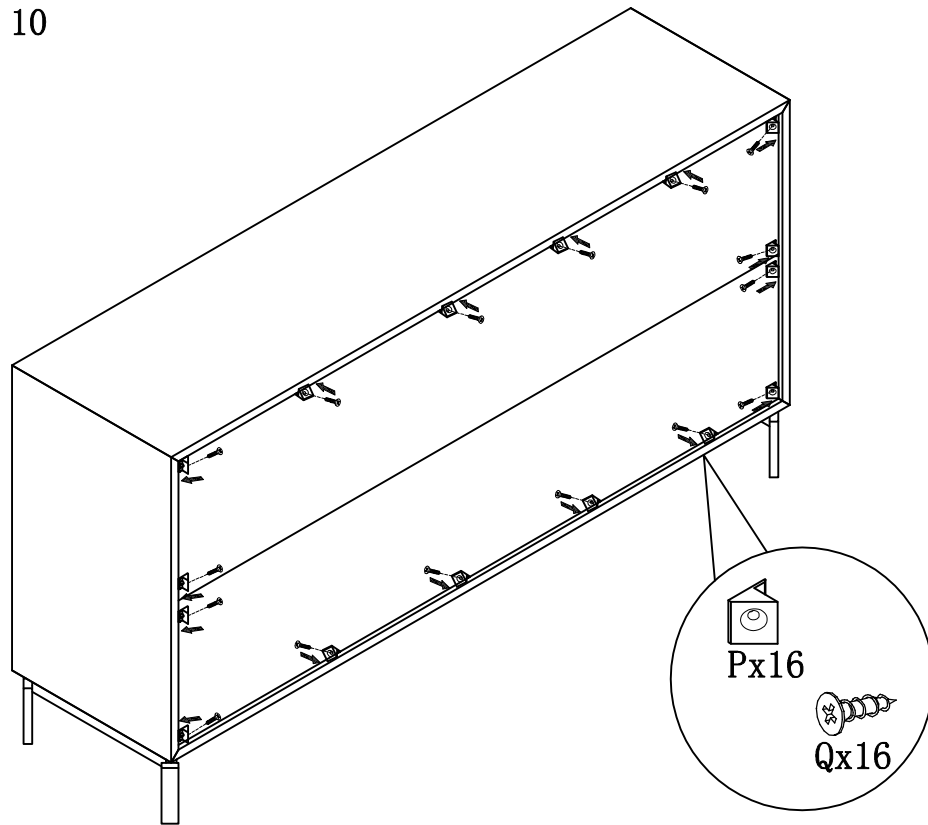

STEP 11 / ETAPE 11

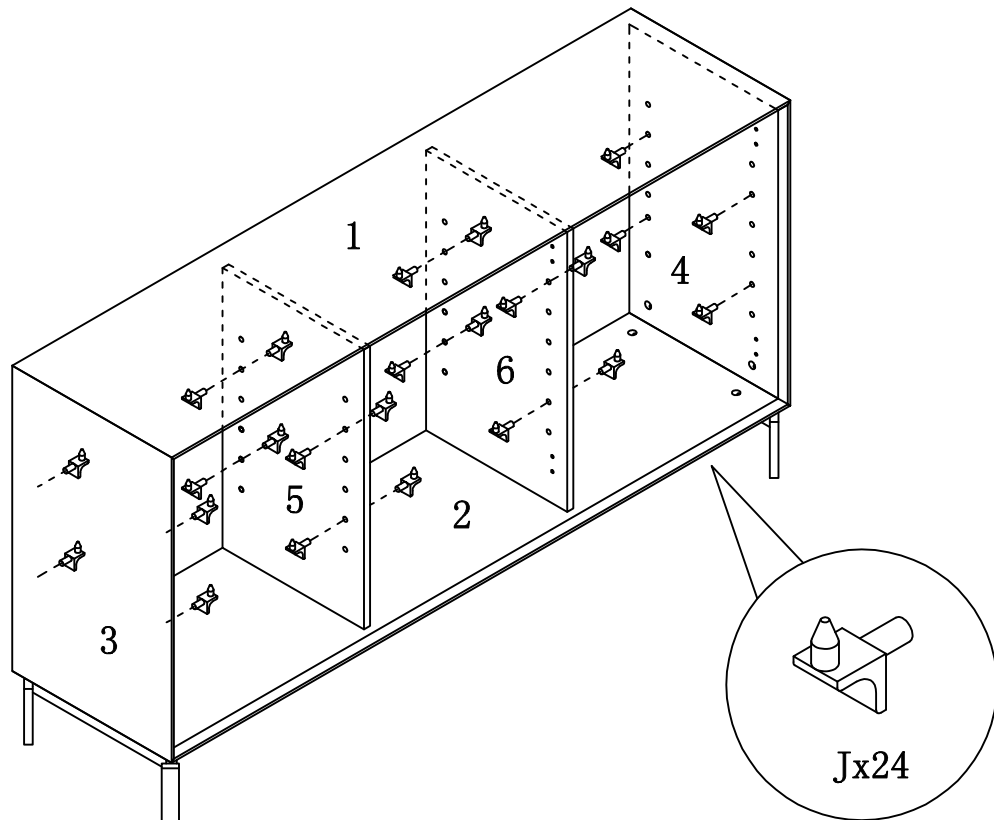

ITEM NO/NO ARTICLE: ALELGAC/253335

STEP 12 / ETAPE 12

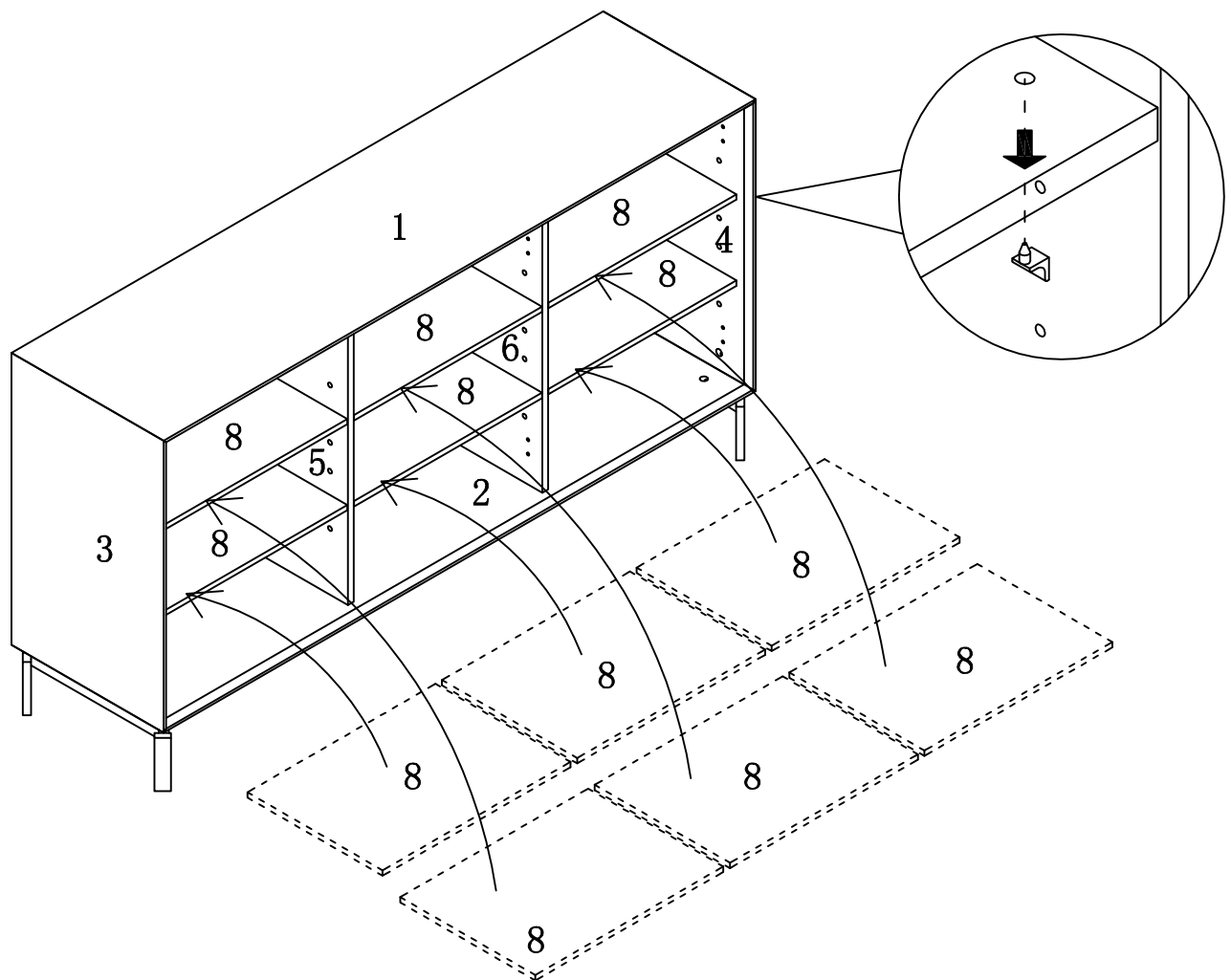

ITEM NO/NO ARTICLE: ALELGAC/253335

STEP 13 / ETAPE 13

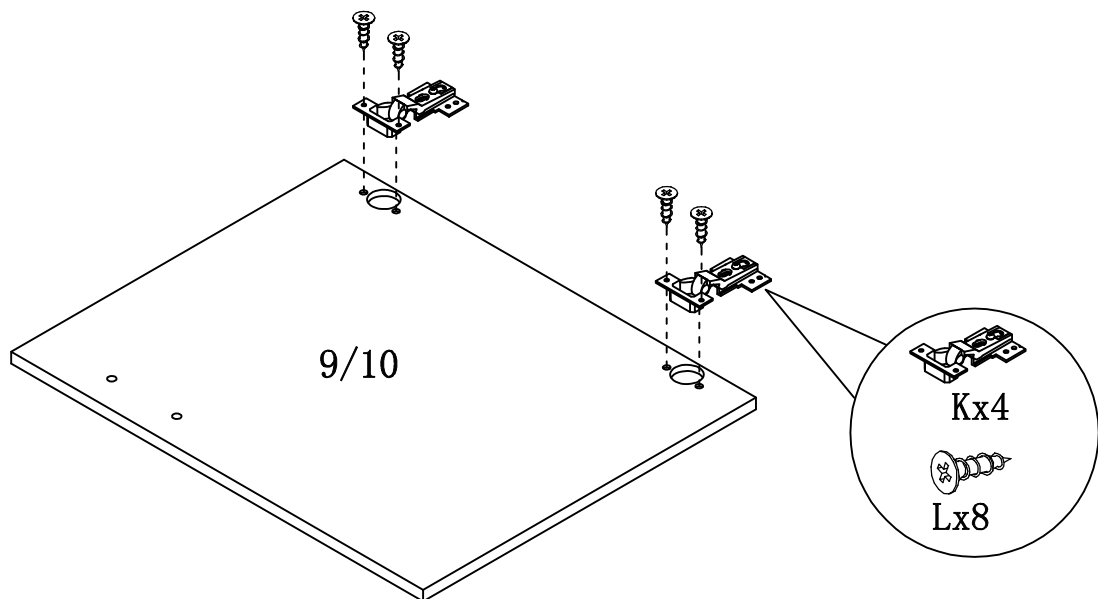

STEP 14 / ETAPE 14

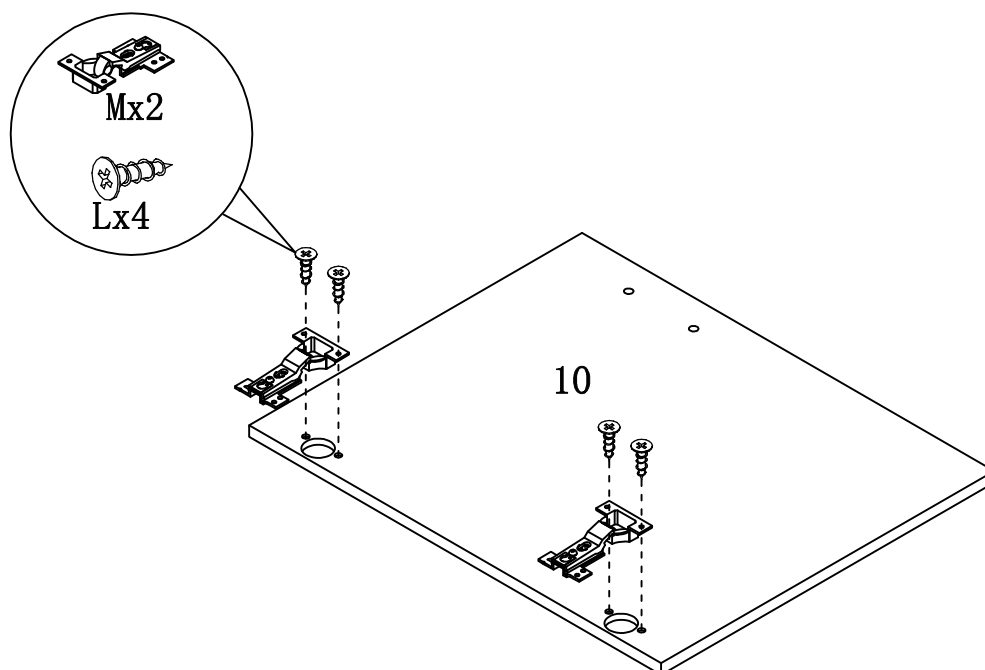

ITEM NO/NO ARTICLE:ALELGAC/253335

STEP 15 / ETAPE 15

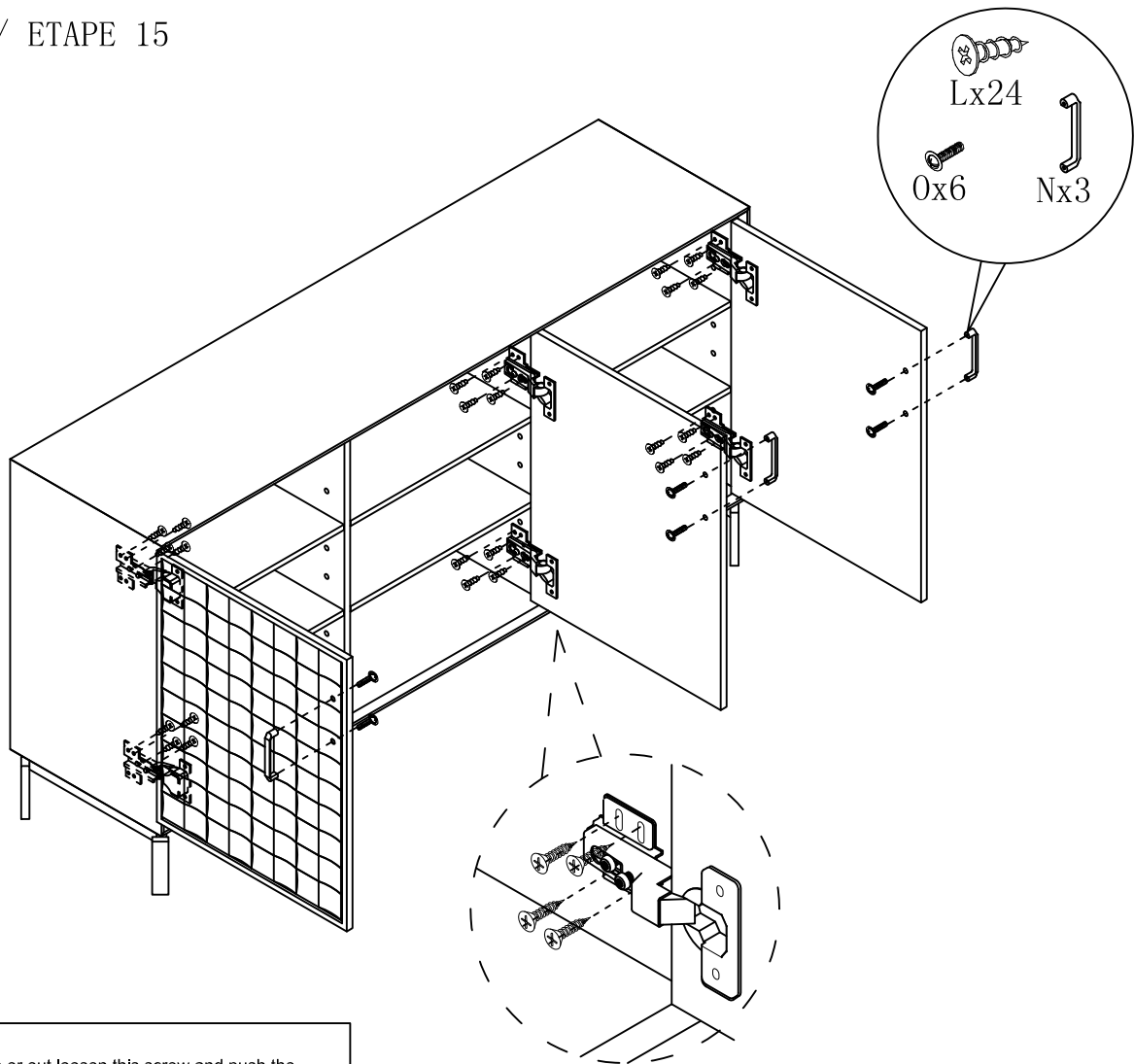

To adjust the door in or out, loosen this screw and push the door further in or push further out then retighten screws.
Pour ajuster l'ouverture de la porte de l'intérieur ou de l'extérieur, dévisser cette vis et pousser la porte vers l'intérieur ou vers l'extérieur puis resserrer les vis.

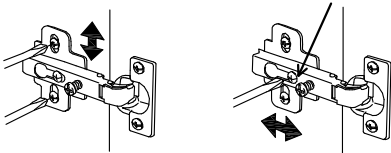

To adjust the door vertically, loosen the top and bottom screws, push the door up or down as necessary, then retighten screws.
Pour ajuster l'ouverture de la porte à la verticale, dévisser les vis de la charnière supérieure et celles de la charnière inférieure, pousser la porte vers le haut ou vers le bas si nécessaire, puis resserrer les vis.

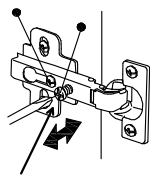

To adjust the door left/right, turn this screw clockwise to move this corner of the door toward the frame, or counterclockwise to move door away from the frame.
Pour ajuster l'ouverture de la porte à gauche ou à droite, tourner cette vis dans le sens des aiguilles d'une montre pour abaisser la porte vers le cadre ou dans le sens contraire des aiguilles d'une montre pour éloigner la porte du cadre.

ANTI-TIPPING STRAP INSTRUCTION

Instructions pour sangle anti-basculement

Quincallerie (Incluse):

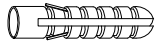

DRYWALL ANCHOR $\phi 8 \times 40$ X 1PCS

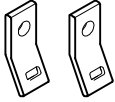

Fixation en métal $12 \times 12 \times 1$ X 2PCS

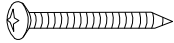

Vis $\phi 5 \times 40$ X 1PCS



Sangle $197 \times 5 \times 1$ X 1PCS



Vis $\phi 4 \times 25$ X 1PCS

Outils requis (Non inclus):

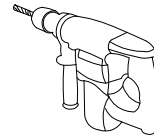

DRILL & DRILL BIT
Perceuse et trépan



LIGHT HAMMER
Marteau léger

Note: Hardware included only compatible with standard drywalls. :Notez que la quincallerie incluse est compatible avec les ancrages de mur standard

Step 1 Étape 1

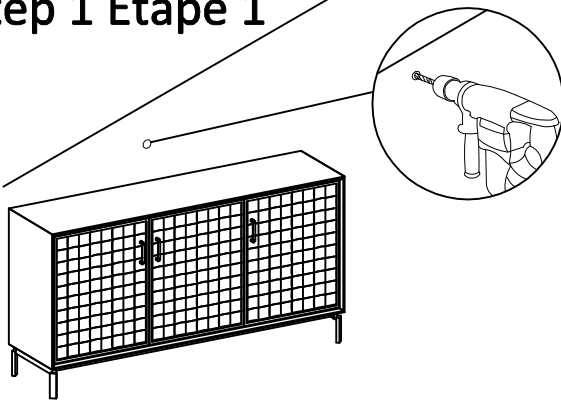

1. Find spot on wall 1" below the top of item.
Placer sur le mur à 1 pouce au-dessus de l'article.
2. Using a drill bit slightly smaller than the gauge of anchor, drill a hole, then place the anchor into wall.
À l'aide d'un trépan légèrement plus petit qu'un ancrage en acier de jauge, percer un trou puis placer l'ancrage dans le mur.

Step 2 Étape 2

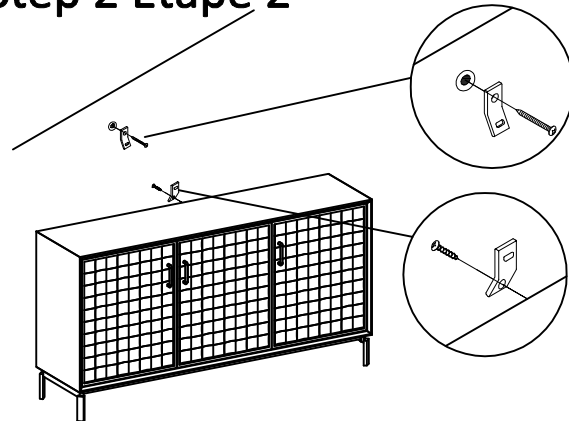

1. Screw the metal bracket into the anchor of wall.
Visser la première fixation en métal à l'intérieur de l'ancrage de mur.
2. Screw the second metal bracket into the back of item along the of soleid frame.
Visser la deuxième fixation à l'arrière de l'article.

Step 3 Étape 3

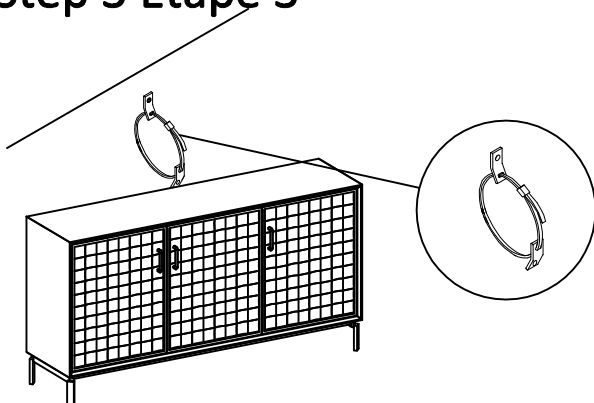

1. Insert strap thru the bracket attached to wall and the second attached to the product.
Insérer la sangle à l'intérieur de la fixation en métal. Elle s'attache facilement sur l'arrière du meuble, l'autre bout étant fixé au mur.
2. Pull tightly: Et puis tirer fermement.